

KNIFE GATE VALVES



Fig.471

Fig.472

Fig.097

FULL BORE

TIGHT SHUT OFF

BI-DIRECTIONAL

DESCRIPTIONS

Valves are manufactured and tested in accordance with MSS-SP-81 class 125 / 150. The knife gate valves are bonnetless, available for both non-rising and rising stem design, with cast solid body, follower and yoke. Valve are resilient seating (compression sealing) with the wire reinforced rubber seat which located below the bore and out of the flow line (full bore), shall be capable of tight shut-off in both direction (bi-directional) and simple in-line seat replacement. Lock nut or stopper on the stem prevents the gate from being over tightened and the o-ring is provided between the layers of packings to sweep the sludge from the gate. The full flow and Bi-directional flow ensure SCI knife gate valves with highest efficiency and reliability.

FEATURES

- Sizes are available from DN 50 mm. - DN 1800 mm.(2"-72")
- Flanges drilling to suit ANSI B16.1, EN 1092, BS 10, ANSI B16.5, AS 2129 and JIS.
- Optional accessories such as Electric actuator, Pneumatic Cylinder, Hydraulic Cylinder and Stem Cover are slao available.
- Seat materials are available in NBR, EPDM, Neoprean, Viton.

APPLICATIONS

Suitable for all type of water, air and steam 100° C or 250° F.
 (For higher temperature, consult factory).

COMPARISONS OF SCI KNIFE GATE VALVES TO MOST OTHER KNIFE GATE VALVES

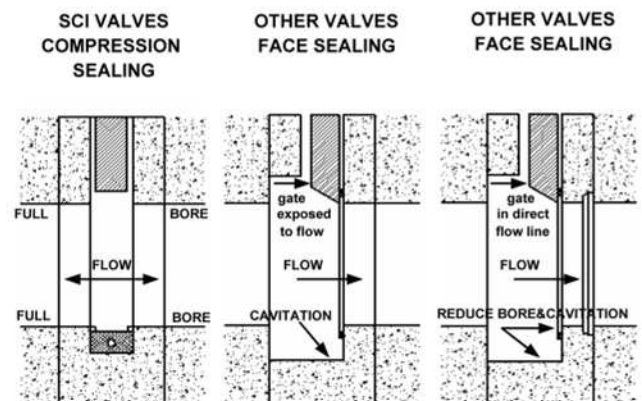

DESIGN SPECIFICATIONS

Fig.472

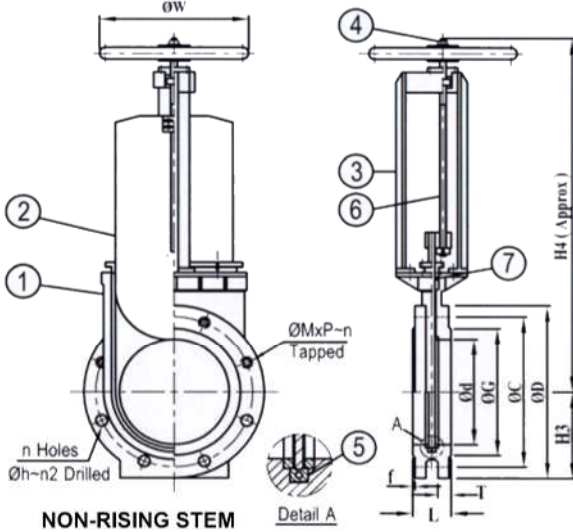
NON-RISING STEM
INSTALLATION DIMENSIONS FOR FLANGE DRILLING PN. 10

SIZE DN	L	ØD	Flange Drilling BS.EN1092-2 PN10				n	n ₁	n ₂	T	f MAX.	H	H1	H2	H3	H4	Øw
			ØC	ØG	Øh	ØMxP											
50	48	165	125	99	19	16x2	4	2	2	15.5	2.5	380	83	435	83	380	225
80	51	200	160	132	19	16x2	8	4	4	15.5	2.5	445	100	530	100	455	225
100	51	229	180	156	19	16x2	8	4	4	15.5	2.5	495	115	600	115	500	270
125	57	255	210	184	19	16x2	8	4	4	18.5	2.5	558	128	688	128	560	270
150	57	285	240	211	23	20x2.5	8	4	4	18.5	2.5	629	143	789	143	623	270
200	70	343	295	266	23	20x2.5	12	6	6	18.5	2.5	735	172	945	172	743	315
250	70	406	350	319	28	24x3	12	6	6	22.5	2.5	840	203	1100	203	890	380
300	76	483	400	370	28	24x3	12	6	6	23	3	940	242	1250	242	954	380
350	76	505	460	429	28	24x3	16	8	8	30	3	1035	260	1395	260	1250	450
400	89	565	515	480	31	27x3	16	8	8	32	3	1510	290	1920	290	1775	450
450	89	615	565	548	31	27x3	20	10	10	32	3	1675	320	2135	320	1890	450
500	114	670	620	609	34	30x3.5	20	10	10	34	3	1715	358	2225	358	1940	700
600	114	780	725	720	37	33x3.5	20	10	10	36	3	1805	420	2415	420	1985	700
700	140	895	840	794	37	33x3.5	24	12	12	40	3	2040	455	2750	455	2240	700
800	140	1015	950	901	41	36x4	24	12	12	44	3	2276	513	3086	513	2476	700
900	170	1115	1050	1001	41	36x4	28	14	14	46	3	2395	563	3305	563	2592	700
1000	170	1230	1160	1112	44	39x4	28	14	14	50	3	2745	628	3755	628	2945	700
1200	200	1455	1380	1328	50	45x4.5	32	16	16	56	3	3330	743	4540	743	3470	700

REMARKS: GEAR OPERATOR REQUIRED FOR Ø400-1200 MM

Fig.097

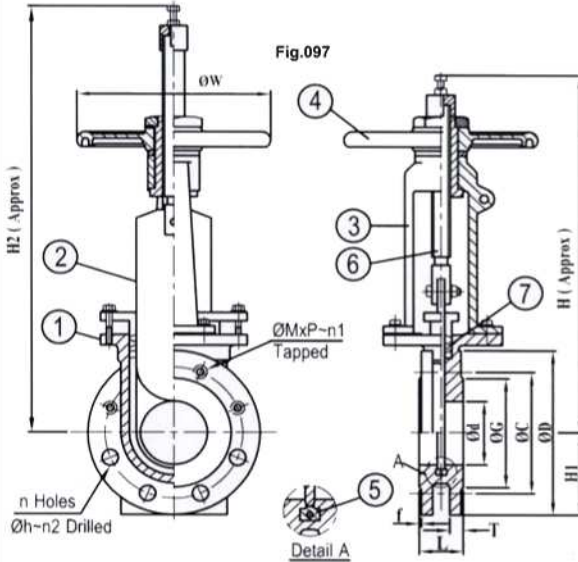

RISING STEM
INSTALLATION DIMENSIONS FOR FLANGE DRILLING PN. 16

SIZE DN	L	ØD	Flange Drilling BS.EN1092-2 PN10				n	n ₁	n ₂	T	f MAX.	H	H1	H2	H3	H4	Øw
			ØC	ØG	Øh	ØMxP											
50	48	165	125	99	19	16x2	4	2	2	15.5	2.5	380	83	435	83	380	225
80	51	200	160	132	19	16x2	8	4	4	15.5	2.5	445	100	530	100	455	225
100	51	229	180	156	19	16x2	8	4	4	15.5	2.5	495	115	600	115	500	270
125	57	255	210	184	19	16x2	8	4	4	18.5	2.5	558	128	688	128	560	270
150	57	285	240	211	23	20x2.5	8	4	4	18.5	2.5	629	143	789	143	623	270
200	70	343	295	266	23	20x2.5	12	6	6	18.5	2.5	735	172	945	172	743	315
250	70	406	355	319	28	24x3	12	6	6	22.5	2.5	840	203	1100	203	890	380
300	76	483	410	370	28	24x3	12	6	6	23	3	940	242	1250	242	954	380
350	76	520	470	429	28	24x3	16	8	8	30	3	1035	253	1395	253	1250	450
400	89	580	525	480	31	27x3	16	8	8	32	3	1510	283	1920	283	1775	450
450	89	640	585	548	31	27x3	20	10	10	32	3	1675	308	2135	308	1890	450
500	114	715	650	609	34	30x3.5	20	10	10	34	3	1715	335	2225	335	1940	700
600	114	840	770	720	37	33x3.5	20	10	10	36	3	1805	390	2415	390	1985	700
700	140	910	840	794	37	33x3.5	24	12	12	40	3	2040	448	2750	448	2240	700
800	140	1025	950	901	41	36x4	24	12	12	44	3	2276	508	3086	508	2476	700
900	170	1125	1050	1001	41	36x4	28	14	14	46	3	2395	558	3305	558	2592	700
1000	170	1255	1170	1112	44	39x4	28	14	14	50	3	2745	615	3755	615	2945	700
1200	200	1485	1390	1328	50	45x4.5	32	16	16	56	3	3330	728	4540	728	3470	700

REMARKS: GEAR OPERATOR REQUIRED FOR Ø400-1200 MM

MATERIALS OF CONSTRUCTION

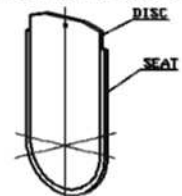
NO.	PARTS	MATERIAL	ASTM DESIGNATION	BS.STANDARD
1	Body	Cast Iron	A 126 Class B	EN1561-EN-GJL-250
		Ductile Iron	A536 Grade 56-45-12	EN1563-EN-GJS-500-7
2	Gate	Stainless Steel	A 276 Type 304	970 Grade 304
		Stainless Steel	A 276 Type 316	970 Grade 316
3	Yoke	Ductile Iron	A536 Grade 56-45-12	EN1563-EN-GJS-500-7
		Steel	A 36	1506
4	Hand Wheel	Cast Iron	A 126 Class B	EN1561-EN-GJL-200
5	Seat	Rubber(NBR)	D 2000 AA 7008	2494
		Rubber(CR)	D 2000 AA 7008	2494
		Rubber(EPDM)	D 2000 AA 7008	2494
		Viton	-	-
6	Stem	Stainless Steel	A 276 Type 304	970 Grade 304
		Stainless Steel	A 276 Type 316	970 Grade 316
7	Packing	PTFE Impregnated Braided		

SEAT CAN BE REPLACED IN LINE

To replace the seat. The valve may stay in the line, the old seat pulled out and a new seat inserted.

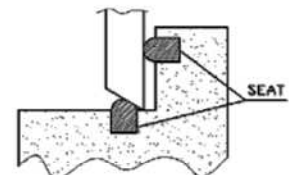

Most other face sealing valves have the seat in the groove or a rebate on the downstream.

SCI CORPORATION Co.,Ltd.

 Factory: 1/12 Moo 2, Samutsakorn Industrial Estate, Soi 7,
 Rama 2 Road, Tahsai, Muang, Samutsakorn 74000, Thailand
 Tel: (6634)440-130 Fax: (6634)440-137 E-mail: sci@scivalve.com

 ISO 9001:2015
 File No.438881 QM
 ISO 14001:2015
 File No.438881 UM